



CP722

POC Transceiver USER MANUAL



1. GENERAL INFORMATION

1.1 【Introduction】

The 4G public network walkie-talkie allows global voice connectivity and communication with clear audio quality and no constraints of distance.

1.2 【Key Features】

- ✧ Linux operation system
- ✧ LTE network
- ✧ Global calling and instant response

1.3 【Accessories】

- ✧ Li-ion battery
- ✧ Belt clip
- ✧ User manual

1.4 【Optional】

- ✧ External speaker/microphone
- ✧ CS88-722 Rapid Charger (6 Slots)

2. CONTROLS AND INDICATORS

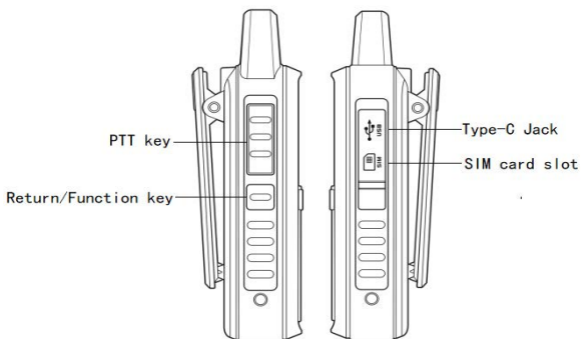
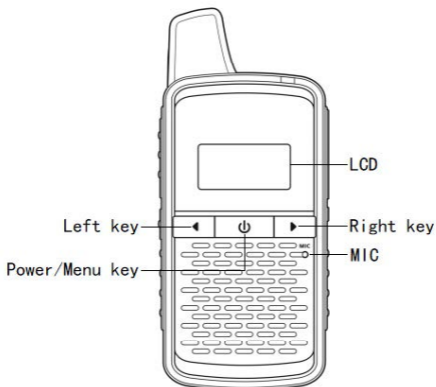

3. CHARGING THE BATTERY

3.1 Charging of on-board battery

Plug the AC plug into the 110-220V AC power output socket.

Align the walkie talkie with battery with the positioning slot and insert it into the charging base for charging, and confirm that the contact is reliable and stable.

3.2 Single battery charging

Plug the AC plug into the 110-220V power output socket.

Align the single battery with the positioning slot and insert it into the charging seat for charging.

Note :When the red indicator light of the charging seat is on, it indicates that the battery is charging ;When the green indicator light of the charging stand is on, it indicates that the charging is completed and the battery is ready for use ;Remove the AC plug of the data cable of the charging stand from the AC power output socket.

4. BASIC OPERATION

4.1 Powering On/Off

To power on the radio, hold down the **【Power】** key for 2 seconds until the screen displays CPS Logo.

To power off the radio, hold down the **【Power】** key for 2 seconds until the screen displays "Power off".

4.2 Adjusting Volume

To increase the volume, press the **【Right key】** key on the radio,

To decrease it, press the **【Left key】** key on the radio.

4.3 Enter Transmitting Status

Press and hold the **【PTT key】**, and the red indicator light will be on. When speaking into the microphone, please keep the distance between the microphone and the mouth about 3-5 cm, and speak in a normal tone, so that the receiver can obtain the best voice quality.

4.4 Enter Receiving Status

When receiving, please release the **【PTT key】** to enter the receiving status. When the channel you are using is called, you can receive the voice.

4.5 Low Power Prompt

When the battery voltage is too low, voice broadcast "low power", when the power is too low, the radio will automatically shut down to protect the module.

5. MENU OPERATION

5.1 Select Group

In standby mode, short press **【Menu key】** key to enter the menu mode, enter **【Select Group】**, press **【Left key】** **【Right key】** key to choose group name, then short press **【Menu key】** key again to confirm, short press **【Return key】** key to return to the previous screen.

5.2 Select Member

In standby mode, short press **【Menu key】** key to enter the menu mode, enter **【Select Member】**, press **【Left key】** **【Right key】** key to choose individual calling users, then short press **【Menu key】** key again to confirm, short press **【Return key】** key to return to the previous screen.

Note: Online users are required to be called.

5.3 Settings

In standby mode, short press **【Menu key】** key to enter the menu mode, enter **【Settings】**, press **【Left key】** **【Right key】** key to choose operation items, then short press **【Menu key】** key again to confirm, short press **【Return key】** key to return to the previous screen.

- Enter **【Power saving mode】** and short press **【Left key】** and **【Right key】** to select the power saving mode, then short press **【Menu key】** key again to confirm.
- Enter **【Auto Screen off】** and short press **【Left key】** and **【Right key】** to select the screen off time, then short press **【Menu key】** key again to confirm.
- Enter **【Audio Quality】** and short press **【Left key】** and **【Right key】** to select the speech quality (4K or 8K), then short press **【Menu key】** key again to confirm.
- Enter **【Tone Setting】** and short press **【Left key】** and **【Right key】** to turn On/Off, then short press **【Menu key】** key again to confirm.
- Enter **【Key Tone】** and short press **【Left key】** and **【Right key】** to select the Key tone On/Off, then short press **【Menu key】** key again to confirm.
- Enter **【Key Lock】** and short press **【Left key】** and **【Right key】** to select the manual/auto, then short press **【Menu key】** key again to confirm.

Note: Long press the **【Return key】 to lock or unlock the keyboard.**

5.4 About

Account information, device information, version information,

6. TROUBLESHOOTING GUIDE

Troubleshooting	Solution
No response after powered on POC radio	Battery power too low: The battery may have run out, replace battery or charge. SIM card failure: check or replace the SIM card Poor battery contact: Reinstall the battery or clean the battery contact points
Insufficient standby time	Battery performance degradation: replace battery
Charging failure	Poor contact :Check contact,replace socket or plug Battery voltage is too low : It will cause no charging display,charge for about half an hour, then unplug and recharge Battery failure : Replace battery Charger failure :Replace or repair the charger
The speaker has no sound or low sound.	Volume setting low: Turn the volume setting up. Water ingress into the speaker grid: Swing the walkie talkie to drain the accumulated water in the speaker grid.
No network connection	Bad signal : Move to the open area and try again Not in the service area :Try to confirm network coverage

1. 概述

1.1【概述】

4G 公網對講機實現全球語音通話，語音清晰宏量，突破通話距離的限制。

1.2【功能描述】

- ◇ Linux 操作系統
- ◇ 支援 LTE 網絡
- ◇ 全球通話和即時響應

1.3【配件】

- ◇ 鋰離子電池
- ◇ 皮帶夾
- ◇ 操作說明書

1.4【可选功能】

- ◇ 耳機麥克風
- ◇ CS88-722 快速充電座（適用於 6 部對講機同時進行充電）

2. 控制鍵及顯示說明

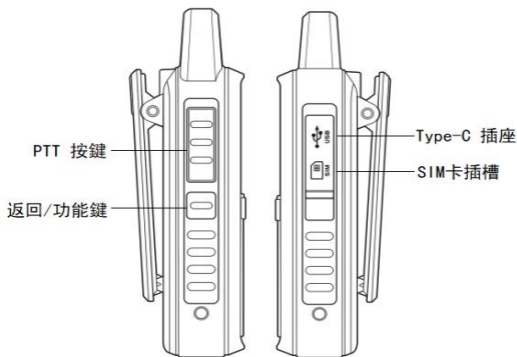

3. 電池充電

4.1 帶機電池充電

將 AC 插頭插在交流電源 110-220V 輸出插座上
將裝有電池的對講機對準定位槽插入充電座中進行充電，
確認接觸可靠穩定。

4.2 單電池充電

將 AC 插頭插在交流電源 110-220V 輸出插座上
將電池對準定位槽插入充電座中進行充電

注：充電座紅色指示燈亮時，表示電池開始充電；
充電座綠色指示燈亮時，表示充電完畢，電池即可使用；
將充電座的數據線的 AC 插頭從交流電源輸出插座取出。

4. 基本操作

4.1 開機和關機

關機狀態下，長按鍵盤【電源】鍵 2 秒時間，直至屏幕顯示 GPS Logo 畫面。
開機狀態下，長按鍵盤【電源】鍵 2 秒時間，直至顯示關機畫面。

4.2 調節音量

開機狀態下，按機器鍵盤【右鍵】可增大音量，按【左鍵】減小音量。

4.3 發送呼叫

按住【PTT 按鍵】，紅色指示燈亮，對著麥克風講話，請保持麥克風與嘴部約 3-5CM 的距離，用平常的聲調講話，以便接收機獲得最佳音質。

4.4 接收呼叫

接收時，請鬆開【PTT 按鍵】進入接收狀態，當您正在使用的通道被呼叫時，您便可以聽到對方的送話音。

4.5 低電量提示

電池電壓過低時，語音播報“電量不足”，當電池電量過低時，對講機自動關機以保護模塊。

5. 菜單操作

5.1 選擇群組

在待機狀態下，短按【菜單鍵】進入菜單模式。進入【選擇群組】，通過【左鍵】【右鍵】選擇相應群組名稱，再次按【菜單鍵】確認，短按【返回鍵】返回上一螢幕。

5.2 選擇用戶

在待機狀態下，短按【菜單鍵】進入菜單模式。進入【選擇用戶】，通過【左鍵】【右鍵】選擇單呼用戶，再次按【菜單鍵】確認，短按【返回鍵】返回上一螢幕。

注：需在線上用戶才可被單呼。

5. 菜單操作

5.3 系統設置

在待機狀態下，短按【菜單鍵】進入菜單模式，進入【系統設置】，通過【左鍵】【右鍵】選擇相應操作項，再次按【菜單鍵】確認，短按【返回鍵】返回上一螢幕。

- 進入【省電模式】，通過【左鍵】【右鍵】選擇省電模式，再次短按【菜單鍵】確認。
- 進入【自動滅屏】，通過【左鍵】【右鍵】選擇熄屏時間，再次短按【菜單鍵】確認。
- 進入【音質設置】，通過【左鍵】【右鍵】選擇通話音質（4K 或 8K），再次短按【菜單鍵】確認。
- 進入【收發提示音】，通過【左鍵】【右鍵】選擇開啟/關閉，再次短按【菜單鍵】確認。
- 進入【按鍵音】，通過【左鍵】【右鍵】選擇開啟/關閉，再次短按【菜單鍵】確認。
- 進入【鍵盤鎖定】，通過【左鍵】【右鍵】選擇手動/自動，再次短按【菜單鍵】確認。

注：長按【返回鍵】可上鎖或解鎖鍵盤。

5.4 本機訊息

賬號信息、設備信息、版本信息。

6. 故障排除指南

問題	解決方案
開機無反應	電池電量不足：電池可能已耗盡，請更換電池或充電 手機卡故障：檢查或更換手機卡 電池接觸不良：重新安裝電池或清洗電池接觸點
待機時間不足	電池效能下降：更換電池
充電故障	接觸不良：檢查接觸情況，更換插座或插頭 電池電壓過低：會導致無充電顯示，先充電約半小時，然後撥下插頭再重新充電 電池故障：更換電池 充電器故障：更換或維修充電器
喇叭沒有聲音或聲音小	音量設定小：把音量設定調大 喇叭柵格進水：甩一甩對講機，將喇叭柵格內的積水排出
無法連接到網絡	訊號太弱：移到開闊處重試 不在服務區：確認網絡覆蓋範圍

TECHNICAL SPECIFICATIONS

Working voltage		DC 3.3V~4.2V
Battery capacity		1000mAh
Antenna impedance		50Ω
Size(H ×W× D)		83x43x21mm
Weight Incl. battery		76g
Network	Radio method	TDD-LTE / FDD-LTE
	Frequency	TDD-LTE : Band 34/Band38/39/40/41 FDD-LTE : Band1/3/5/8



[http:// www.cps-telecom.com](http://www.cps-telecom.com)

 is the registered trademark of CPS Telecom Limited, Hong Kong

©2023 CPS Telecom Limited

CPS20240828722V.1.2